

### Dimensions

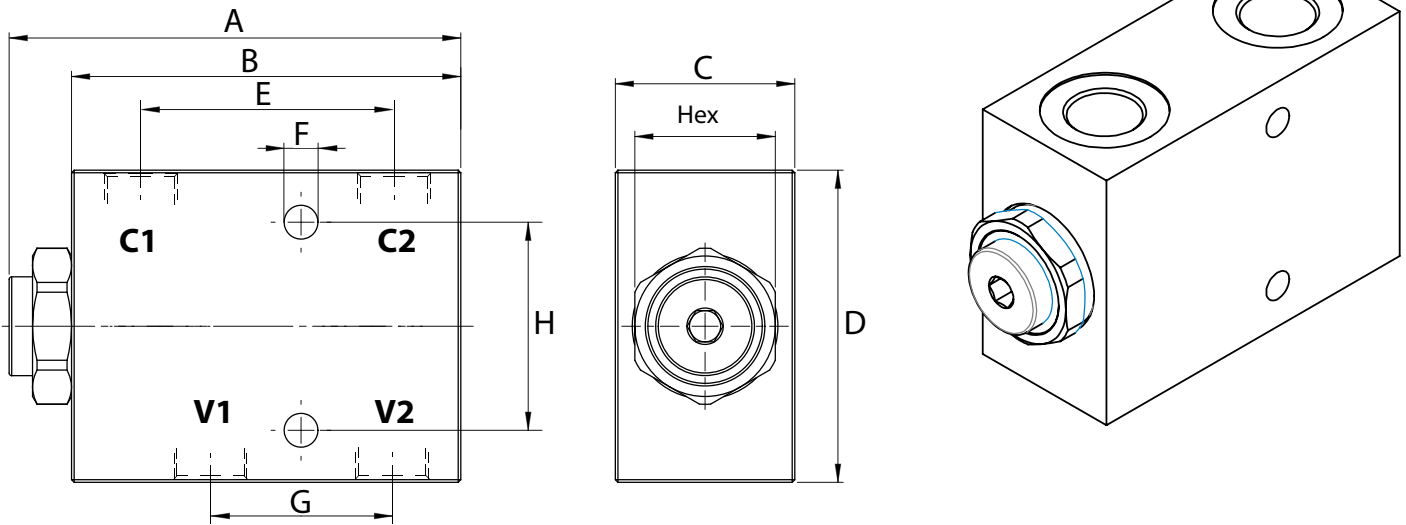

Size	C1-C2 V1-V2 BSP	A	B	C	D	E	F	G	H	Hex	Weight kg
02	3/8	95	83	35	60	49	6,5	32	40	27	0,52
25	1/2	95	83	35	60	49	6,5	32	40	27	0,48

### Hydraulic Symbol

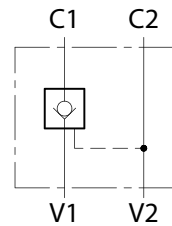

### Curves

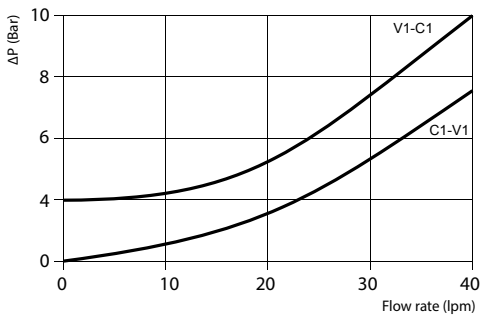

### Features

Size	02	25
Max Pressure (bar)	260	260
Max Flow (lpm)	35	35
Pilot Ratio	1:7	1:7
Cracking Pressure (bar)	4	4

**Materials:** Aluminium manifold, hardened steel inner parts.

### Ordering Code

**LVSL**    --

	Size BSP
<b>02</b>	3/8
<b>25</b>	1/2

**Ordering Code Example:** LVSL02 = 3/8 BSP, 35 lpm.